

BD600A > FORGED ALUMINIUM
CRANKED D RING. FLAT VERSION
AVAILABLE.

ISC MANUFACTURES AN EXTENSIVE
RANGE OF HARNESS COMPONENTS ALL
HARNESS COMPONENTS CONFORM TO
RELEVANT EUROPEAN AND ANSI STANDARDS.

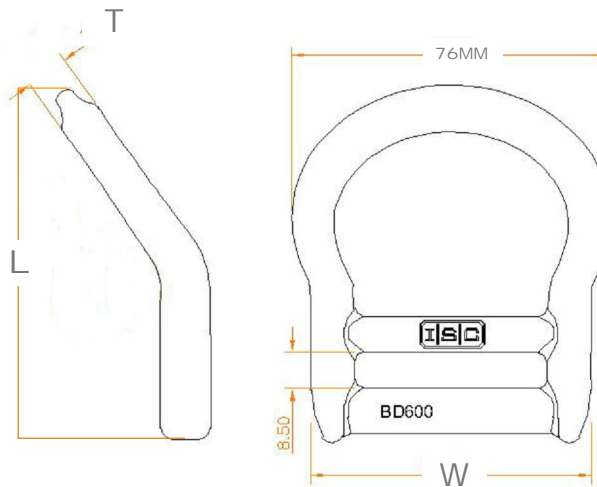

1

2

DIMENSIONS >
LENGTH > 84MM
WIDTH > 67MM
THICKNESS > 10MM

MATERIAL > ALUMINIUM
STRENGTH > 25KN
FINISH > ANODISED
QUALITY > 100% INSPECTED
WEIGHT > 72kg