

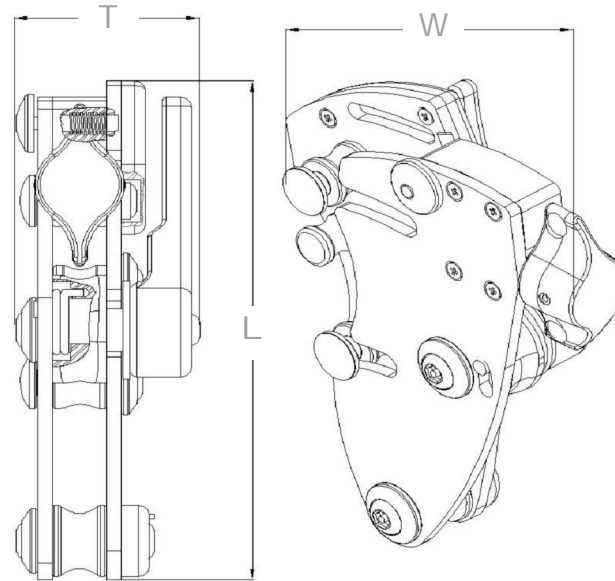

RP400> PRO ALP DESCENDER.

ISC MANUFACTURES ARANGE OF DESCENDERS.  
ALL DESCENDERS CONFORM TO RELEVANT  
EUROPEAN AND ANSI STANDARDS.



**DIMENSIONS >**  
**LENGTH >** 150MM  
**WIDTH >** 90MM  
**THICKNESS >** 45MM

**MATERIAL >** ALUMINIUM  
**ROPE DIAMETER >** 10.5- 12.7MM  
**MAX RATED LOAD >** 100KG  
**MEETS >** prEN 12841  
**FINISH >** ANODISED  
**QUALITY >** 100% INSPECTED  
**WEIGHT >** 580G