

Gg201 > LARGE GIRDER GRIP FOR CONCRETE FORM WORK.

ISC MANUFACTURES AN EXTENSIVE RANGE OF ANCHOR DEVICES. ALL ANCHOR DEVICES CONFORM TO RELEVANT EUROPEAN AND ANSI STANDARDS.

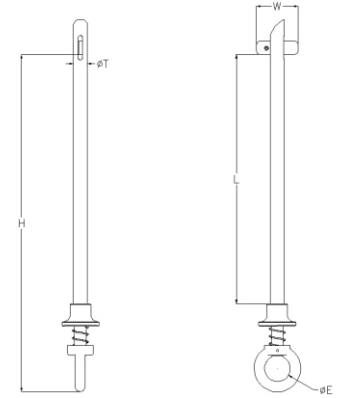
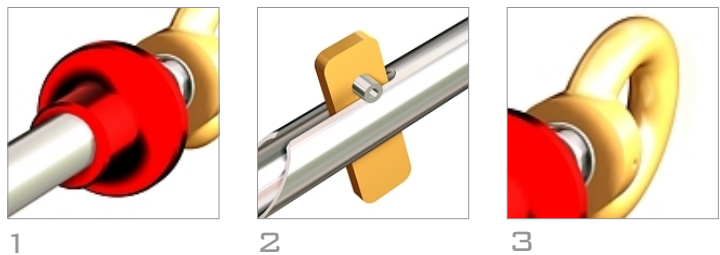
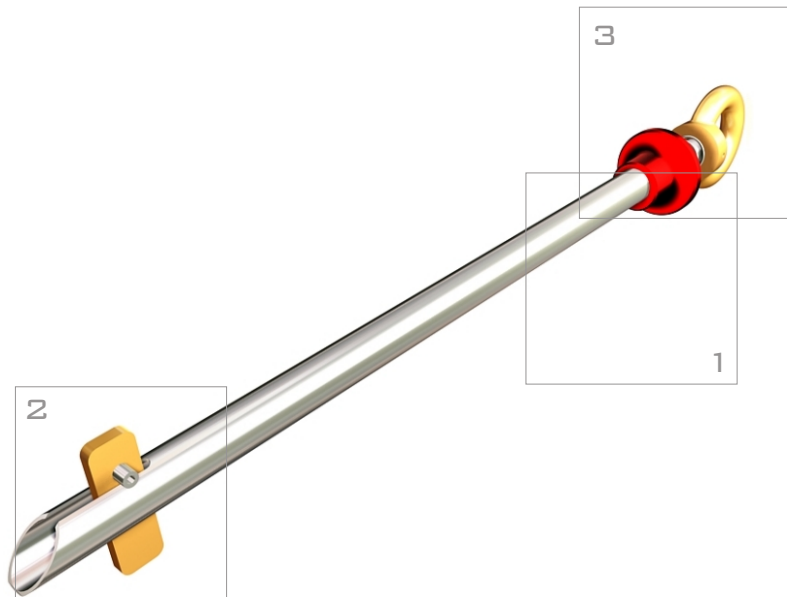

DIMENSIONS >
HEIGHT > 450MM
LENGTH > 335MM
WIDTH > 56MM
THICKNESS > 19MM

FEATURES > THIS ANCHOR HAS BEEN DESIGNED TO PROVIDE SECURE ANCHOR POINTS THROUGH CONCRETE OR SOLID BRICK WALLS AND FLOORS OF BETWEEN 250MM AND 300MM THICK. TO FIT HOLE SIZE 20 - 25MM

MATERIAL > HIGH TENSILE STEEL, AND ALUMINIUM.

MINIMUM BREAKING LOAD > 28KN

APPROVED STANDARDS > CE CERTIFIED TO BSEN 795.

FINISH > PLATED, POLISHED AND ANODISED.

QUALITY > PROOF LOADED TO 16KN ON REQUEST. 100% INSPECTED AND FUNCTION TESTED.

WEIGHT > 1165G

INTERNATIONAL SAFETY COMPONENTS LTD
 Unit 1, Plot 2, Llandygai Industrial Estate,
 Bangor
 Gwynedd
 LL574YH

T - +44 (0) 1248 363 110
F - +44 (0) 1248 372 348
E - sales@iscwales.com
W - www.iscwales.com